

* In case of short time user (e.g. for office-, hotel-, commercial building) only possible on lower parking space and only if technically adjusted, ask WÖHR! Or with attendant or valet parking all levels are possible for short time user.

Parklift 421-2,0: Load per platform max. 2000 kg (load per wheel max. 500 kg)

or:

Parklift 421-2,6: Load per platform max. 2600 kg (load per wheel max. 650 kg)

Dimensions in cm

Installation indoor

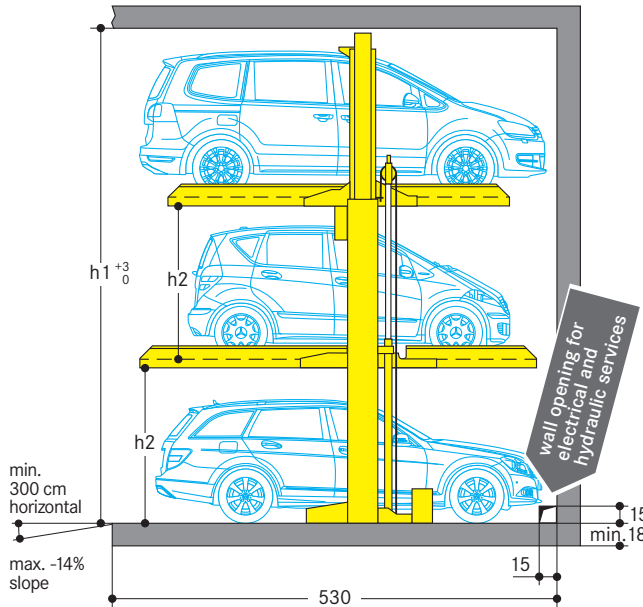

Installation outdoor

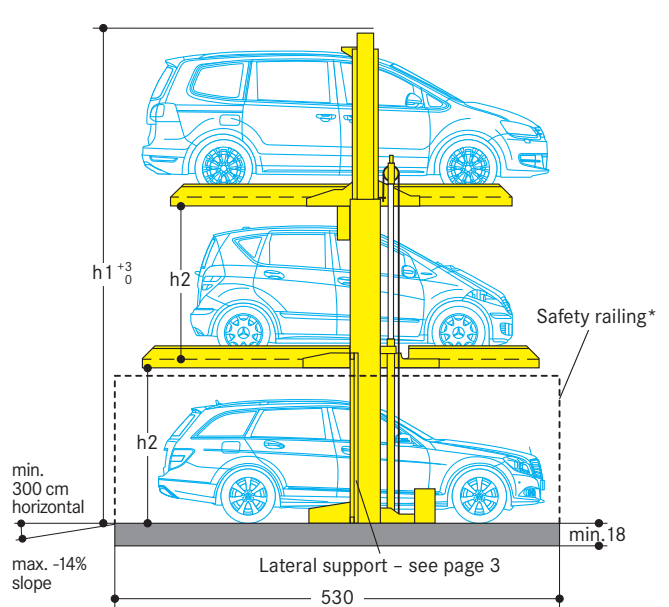

* Rear and lateral site safety railing, compliant to the DIN EN ISO 13857 standard requirements, is to be supplied by the customer. The height of the safety railing is dependent on the distance from the moving parts.

	Parklift 421-500	Parklift 421-530	Parklift 421-560	Parklift 421-590
Height h1	500	530	560	590
Height h2	155	165	175	185
Car height	150	160	170	180

	Parklift 421-500	Parklift 421-530	Parklift 421-560	Parklift 421-590
Height h1	500	530	560	590
Height h2	155	165	175	185
Car height	150	160	170	180

Function

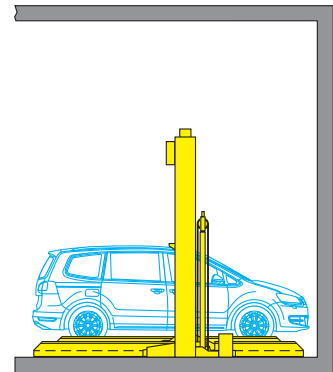
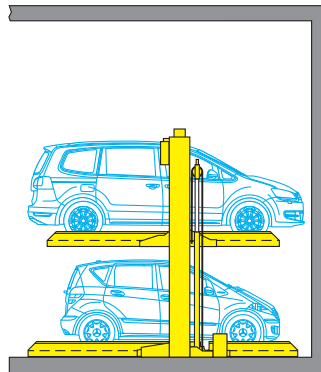
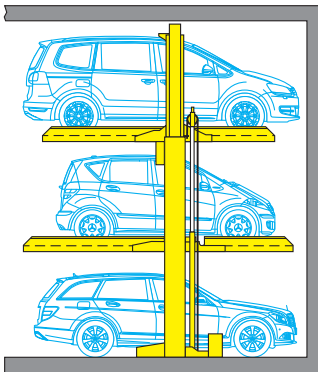

Before lowering the platforms, the car on the entrance level must be driven off!

Before lowering the upper platform, the car on the middle level must also be driven off!

Notes

1. Clear platform width of 250/260 cm for car widths of 190 cm. For large touring sedans we recommend a clear platform width of at least 260/270 cm.
2. According to ISO 3864 the floor has to be marked with 10 cm wide yellow-black stripes at a distance of 35 cm from the platform edge by the purchaser (see "statics and construction requirements" on page 2).
3. It is not possible to have channels or undercuts and/or concrete haunches along the floor-to-wall joints. In the event that channels or undercuts are necessary, the system width needs to be reduced or the installation width needs to be wider.
4. The manufacturer reserves the right to construction or model modifications and/or alterations. Furthermore, the right to any subsequent part modification and/or variations and amendments in procedures and standards due to technical and engineering progresses in the art or due to environmental regulation changes, are also hereby reserved.

Width dimensions · Installation indoor

All dimensions shown are minimum. Construction tolerances must be taken into consideration.
All dimensions in cm.

Access to the garages to be minimum 300 cm horizontally, with a slope level of maximum -14 %.

Single unit

Fixing to the wall*

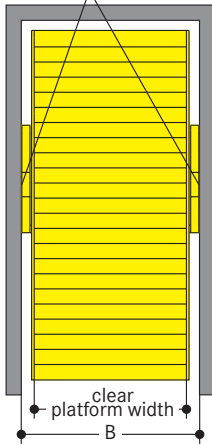

Space required B	gives clear platform width upper level	middle level
260	220	230
270	230	240
280	240	250
290	250	260
300	260	270

Row arrangement

Fixing to the wall*

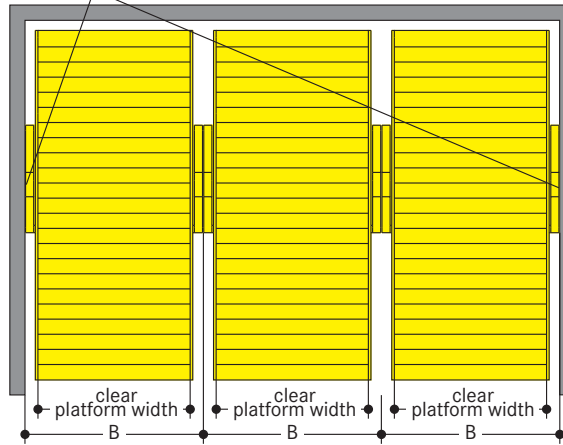

Wall openings required between partitions for electrical and hydraulic conduits must be provided where applicable. Wall openings may not be closed after installation.

The driving aisle width to be compliant with country regulations locally in force.

* Fixing to the wall on one side (either left or right), is sufficient. The wall shall then be subject to both compressive and traction forces (see statics and construction requirements). With a two-sided fixing system, the wall shall only be subject to compressive forces.

Statics and construction requirements · Installation indoor

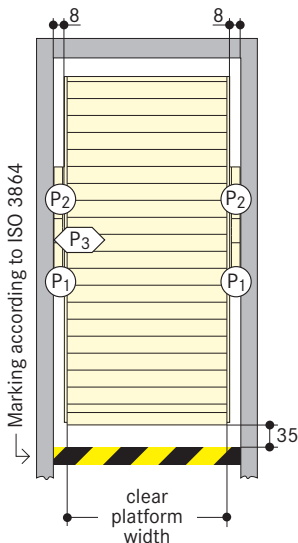
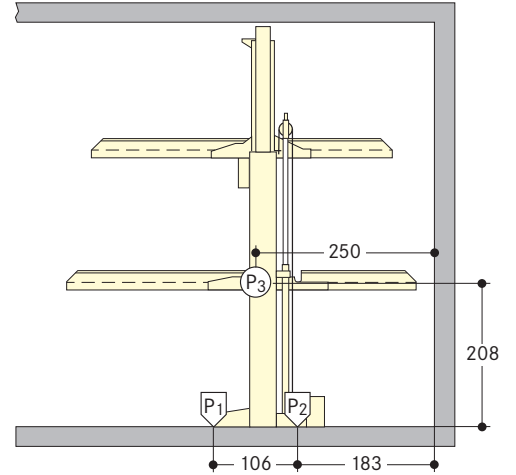
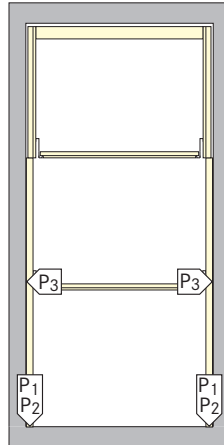
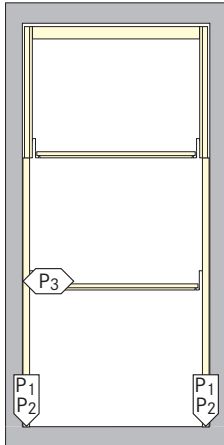

One-sided support	
421-2,0	421-2,6
P1 = +20 kN *	+25 kN
P2 = +18 kN	+21 kN
P3 = ± 3 kN	± 3 kN

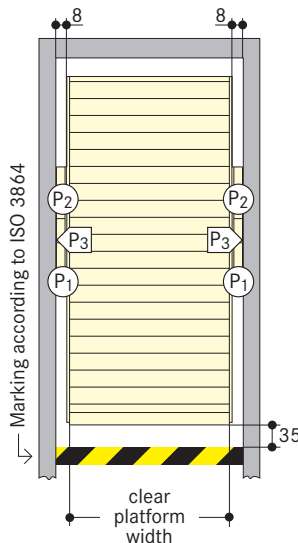

Two-sided support	
421-2,0	421-2,6
P1 = +20 kN *	+25 kN
P2 = +18 kN	+21 kN
P3 = + 3 kN	+ 3 kN

The system units are locked onto the construction frame points of support using heavy-duty dowels (having a drilling depth of 10 to 12 cm).

Base plate thickness minimum 18 cm! Concrete quality according to the static requirements of the building, but for the dowel fastening we require a concrete quality of min. C20/25.

Special foundations are required with asphalt floors or paving-stones.

* all static loadings include the weight of the car

Width dimensions · Installation outdoor

All dimensions shown are minimum. Construction tolerances must be taken into consideration.
All dimensions in cm.

Access to the garages to be minimum 300 cm horizontally, with a slope level of maximum -14 %.

Single unit

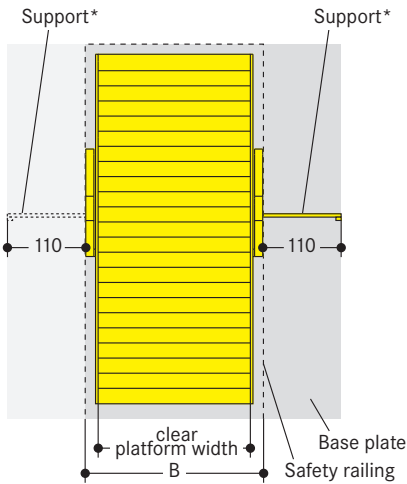

Row arrangement

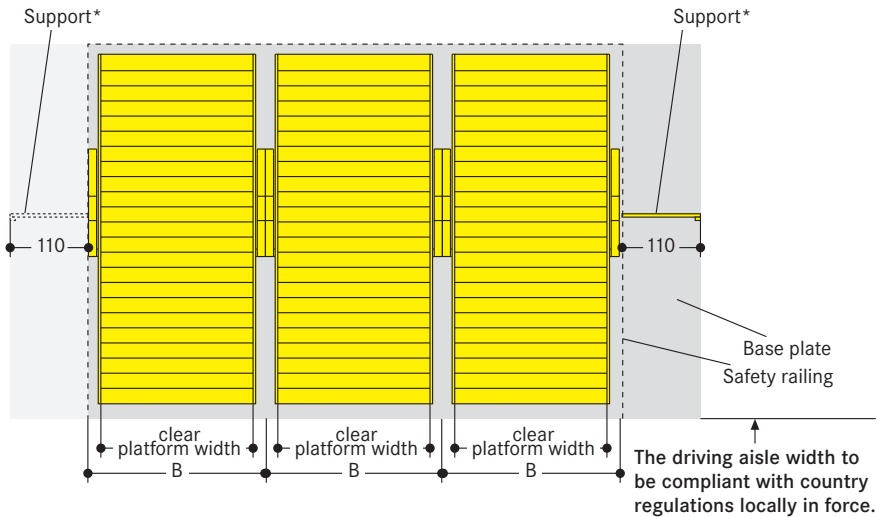

Space required B	gives clear platform width	
	upper level	middle level
260	220	230
270	230	240
280	240	250
290	250	260
300	260	270

* A one-sided support (either left or right) is sufficient. The base plate shall then be subject to both compressive and traction forces (see statics and construction requirements).
With a two-sided support system the base plate shall only be subject to compressive forces.

Statics and construction requirements · Installation outdoor

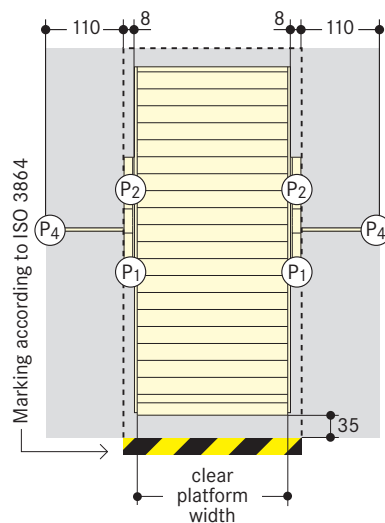
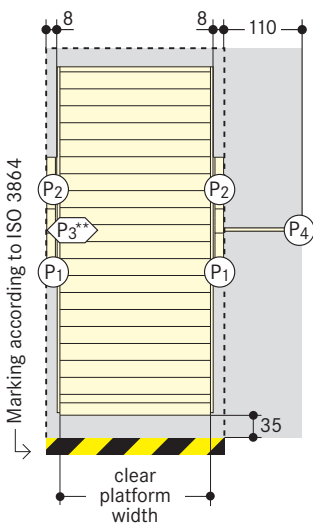
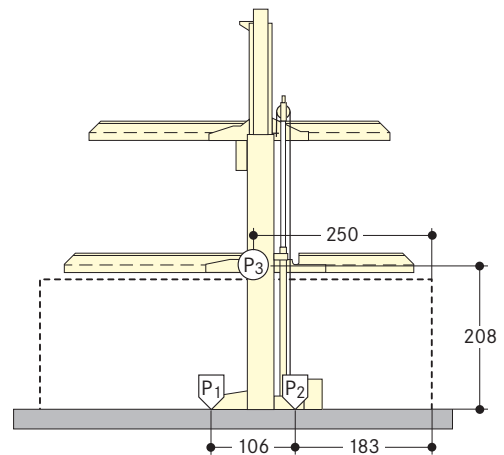
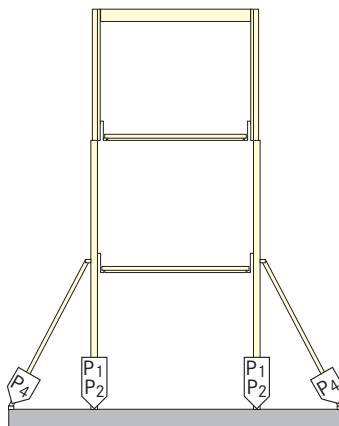
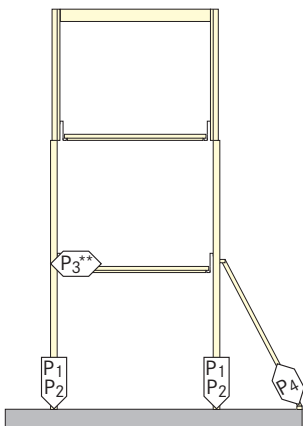

The system units are locked onto the construction frame points of support using heavy-duty dowels (having a drilling depth of 10 to 12 cm).

Base plate thickness minimum 18 cm! Concrete quality according to the static requirements of the building, but for the dowel fastening we require a concrete quality of min. C20/25.

Special foundations are required with asphalt floors or paving-stones.

For outdoor installation sideways supporting is necessary; available against additional charge.

The wind load compliant to DIN 1055 Part 4 amounts to 0.5 kN/m².

The snow load compliant to DIN 1055 Part 5 amounts to 0.75 kN/m².

One-sided support

P1 = +27 kN*
P2 = +23 kN
P3 = +10 kN**
P4 = ±22 kN

Two-sided support

P1 = +27 kN*
P2 = +23 kN
P4 = +22 kN

* all static loadings include the weight of the car

** P3 (compressive and traction forces) only occur when the system is anchored to a building on one side. If the system is anchored to a building, lateral support (P4) can be omitted.

Electrical datas

Item	Performance	Quantity	Designation	Position	Frequency
1	by customer	1 unit	electric meter	in the feed cable	
2	by customer	1 unit	fuse or automatic circuit breaker 3x25 A slow blow acc. to DIN VDE 0100 p. 430	in the feed cable	1 per power pack
3	by customer	as locally required	acc. to local power supply regulations 3 Ph + N + PE*	feed cable to main switch	1 per power pack
4	by customer	each 10 m	equipotential bonding safety lead-out connection	corner pit floor/rear wall	
5	by customer	1 unit	equipotential bonding safety compliant to the DIN EN 60204 standard	from the lead-out connection to the system	1 per Parklift
6	by customer	1 unit	marked main switch, lockable to prevent unauthorized switching on	above operating device	1 per power pack
7	by customer	10 m	PVC control cable with marked strands and protective conductor 5 x 2,5 ²	from main switch to hydraulic power pack	1 per power pack

Items 8–16 are included in Wöhr's scope of delivery unless otherwise specified in the offer/order.

* DIN VDE 0100 part 410 + 430 (not under permanent load) 3PH+N+PE (three-phase current) Note: Where a door is used to close the garage, the manufacturer of the door must be consulted before the electric cable is laid.

The electrical components supplied by the manufacturer must be connected in accordance with the appropriate wiring diagram and local regulations. German VDE electrical requirements must be adhered to, in order to validate the TÜV tested circuit.

The electrical supply to the power pack(s) must be provided prior to or during installation to

enable our fitters to complete their work satisfactorily and to check the correct functioning of the units.

In compliance with the DIN EN 60204 standard provisions, all systems must be connected directly on site with an earthed equipotential bonding. The lead-out connection must be at a 10 m distance!

Noise protection

Basis is the German DIN 4109 "Noise protection in buildings".

With the following conditions required 30 dB (A) in rooms can be provided:

- noise protection package from our accessory
- insulation figure of the construction of min. $R'_w = 57$ dB
- walls which are bordering the parking systems must be done as single wall and deflection resistant with min. $m^2 = 300$ kg/m²
- solid ceiling above the parking systems with min. $m^2 = 400$ kg/m²

At differing constructional conditions additional sound absorbing measures are necessary.

The best results are reached by separated sole plates from the construction.

Increased noise protection:

If increased noise protection must be provided planning has to be confirmed on a project basis by Wöhr (further building measures are required).

Temperature

The installation is designed to operate between +5°C and +40°C. Atmospheric Humidity: 50% at +40°C. If the local circumstances differ from the above please contact Wöhr.

Hydraulic power packs

For the accommodation of the hydraulic power packs an additional space is required which will be determined during the verifications of the drawings, e.g. in a wall recess.

Dimensions

All dimensions shown are minimum. Construction tolerances must be taken into consideration. All dimensions in cm.

Installation diagram

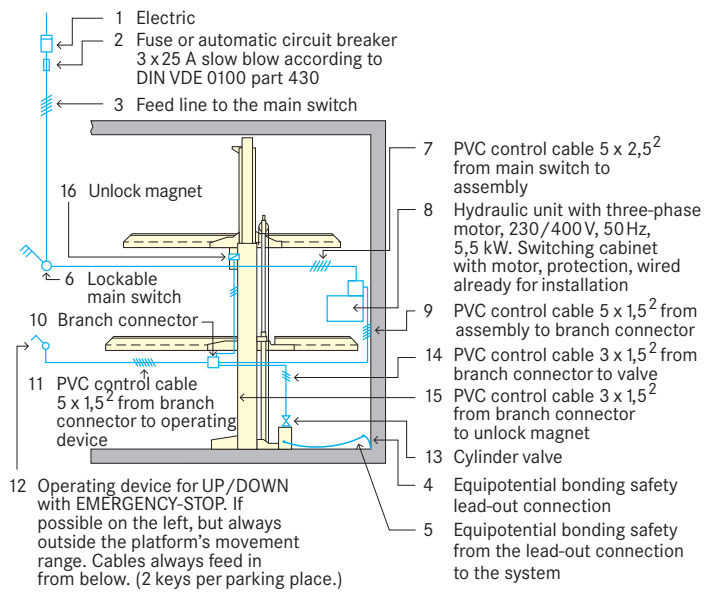

Conformity test

All our systems are checked according to EC machinery directive 2006/42/EC and EN 14010.

Railings

If walkways are arranged directly to the side or behind the systems, railings have to be provided acc. EN ISO 13857 by client acc. to local requirements, height min. 200cm.

Notes

In case of lower cars with spoilers, contact Company Wöhr or local agent (see "clearance profile").

Maintenance

WÖHR and our foreign partners have an assembly and customer network. Annual maintenance is performed at conclusion of a maintenance contract.

Protection against corrosion

Independent of a maintenance workings has to be carried out acc. to Wöhr Cleaning and Maintenance Instruction regularly.

Clean up galvanized parts and platforms of dirt and road salt as well as other pollution (corrosion danger)!

Pit must be always ventilated and deaired well.

Fire safety

Each and every fire safety requirement and all possible mandatory item(s) and equipment(s) (fire extinguishing systems and fire alarm systems, etc.) are to be provided by the customer.

Clearance profile (standard car)

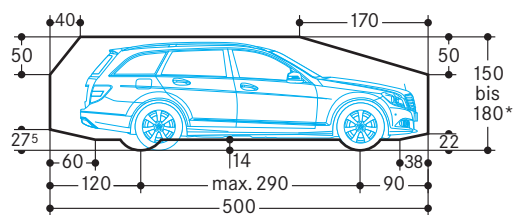

* The total car height includes roof rail and antenna fixture must not exceed the mentioned max. height dimension.